

Virtual Inertia Grid Control with LED Lamp Driver

Colloquium for the Master Thesis – 08.06.2016
Faculty 07 – Electrical Power Engineering

Examiner: Prof. Dr. Eberhard Waffenschmidt

Co-examiner: Prof. Dr. Christian Dick

Content

- Motivation
- Substitution of the rotating inertia
- Development process
- Measurement results
- Conclusion

Motivation

- Maintaining the balance of the power generation and consumption
- Compensation with additional power (instantaneous reaction) from rotating inertia
- With more renewable energy sources → less conventional generators
- Solution: using the feed-in inverters as “virtual inertia”
 - The need of an electric storage
 - The existing inverters are not easy to be modified

Idea: virtual inertia control in electronic power supply of loads

Motivation

Instantaneous power in the European ENTSO-E grid :

- worst case: 3 GW load step
 - 5W power
 - 50Ws energy
- } per installed kW

Instantaneous power in Germany

- 372 MW power
- 3720 MWs energy

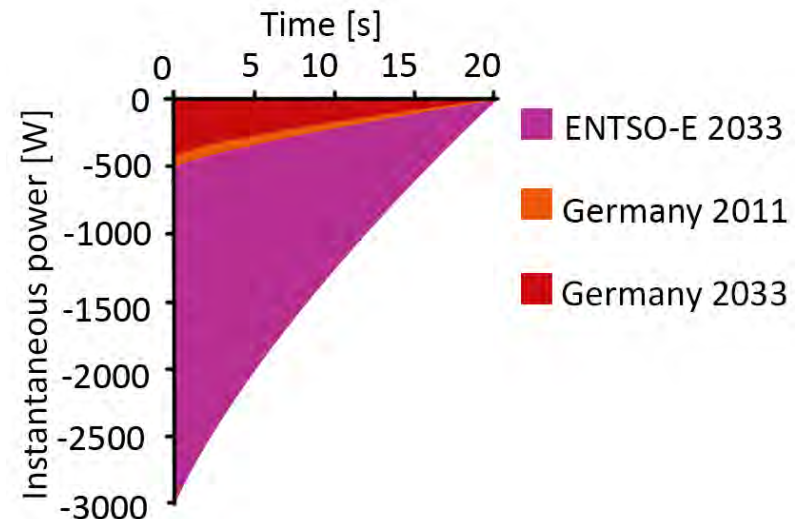

Instantaneous power reserve for the worst case of a sudden load change of 3 GW in European ENTSO-E grid [1]

Substitution of the rotating inertia

In case of an error:

- If there is not enough rotating inertia in the power network
 - Power deficit → decreasing frequency

$$\text{Where } \frac{\Delta P(t)}{P_0} = T_A \cdot \frac{d}{d(t)} \cdot \frac{\Delta f(t)}{f_0}$$

ΔP : power which is needed by the load

P_0 : nominal power of the power network

T_A : time constant (20s)

Δf : deviation from the nominal frequency

f_0 : nominal frequency

Substitution of the rotating inertia

Where

$\Delta U_c/U_0$: voltage fluctuation
in the capacitor
 $\Delta f/f_0$: frequency fluctuation

$$\frac{\Delta U_C(t)}{U_0} = T_A \cdot \frac{1}{2} \cdot \frac{P_0}{E_0} \cdot \frac{\Delta f}{f_0} \quad [2]$$

Approach

- intermediate capacitor
- in LED Lamp Drivers

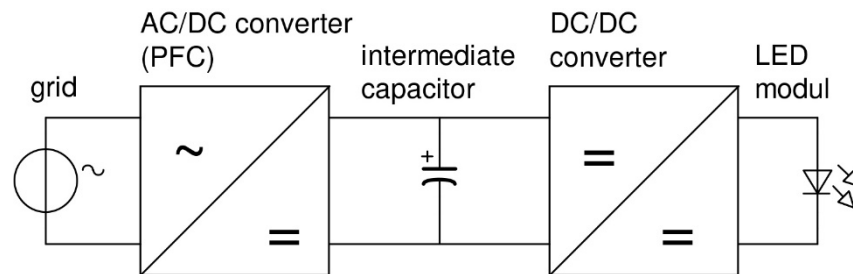

Development process – Control method

- Controlling the PFC (Power Factor Correction) circuit in the LED driver
 - Responsible of the charge of the intermediate capacitor
 - Controls the value of the real power of the driver [3]

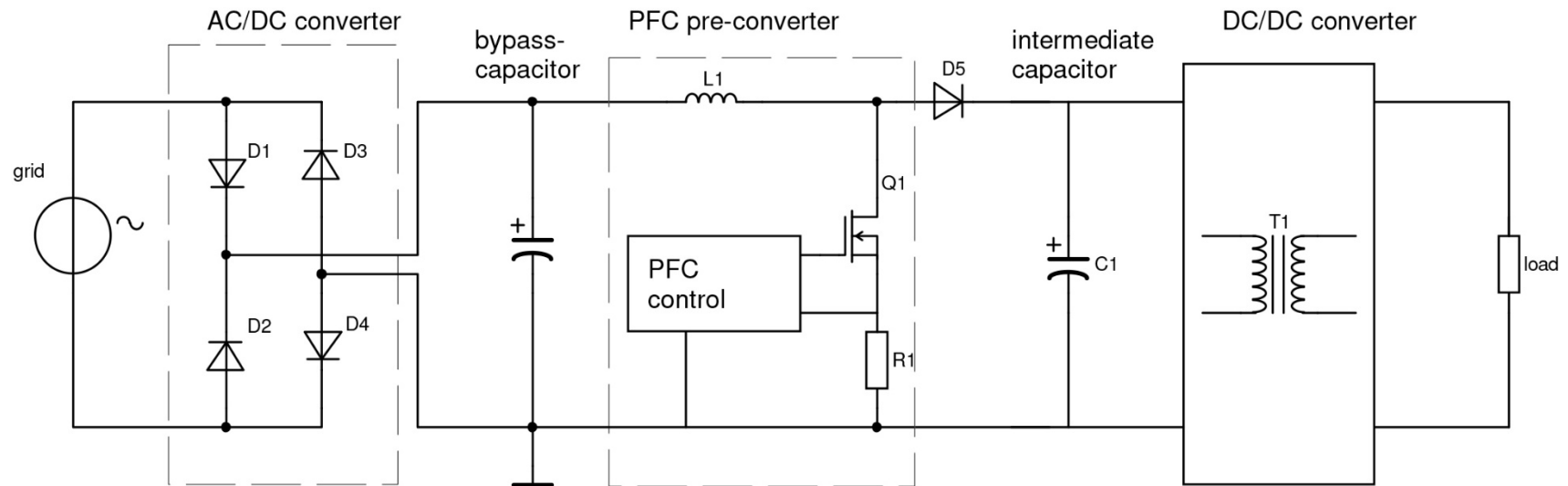

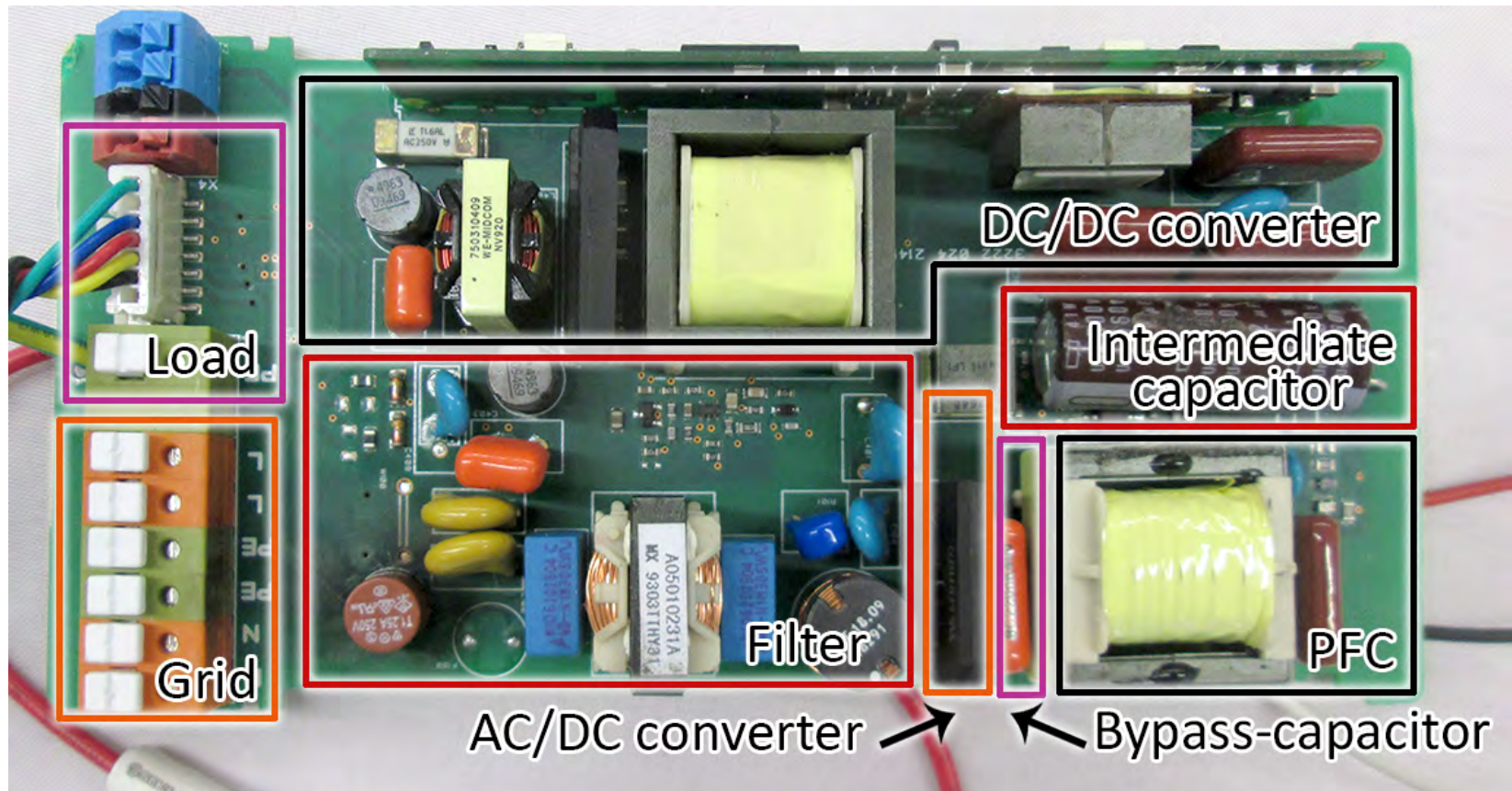

Development process - PFC

- Controlling the PFC
 - TDA4863
 - VSENSE input
- $f_{grid} > 50\text{Hz} \rightarrow$
 - $U_{control}$ decreasing
 - U_{c0} increasing
- $f_{grid} < 50\text{Hz} \rightarrow$
 - $U_{control}$ increasing
 - U_{c0} decreasing

Without control: $U_{control} = 2.5\text{V}$
 Maximum: $U_{control} = U_{VCC} = +15\text{V}$
 Minimum: $U_{control} = \text{GND} = +0\text{V}$

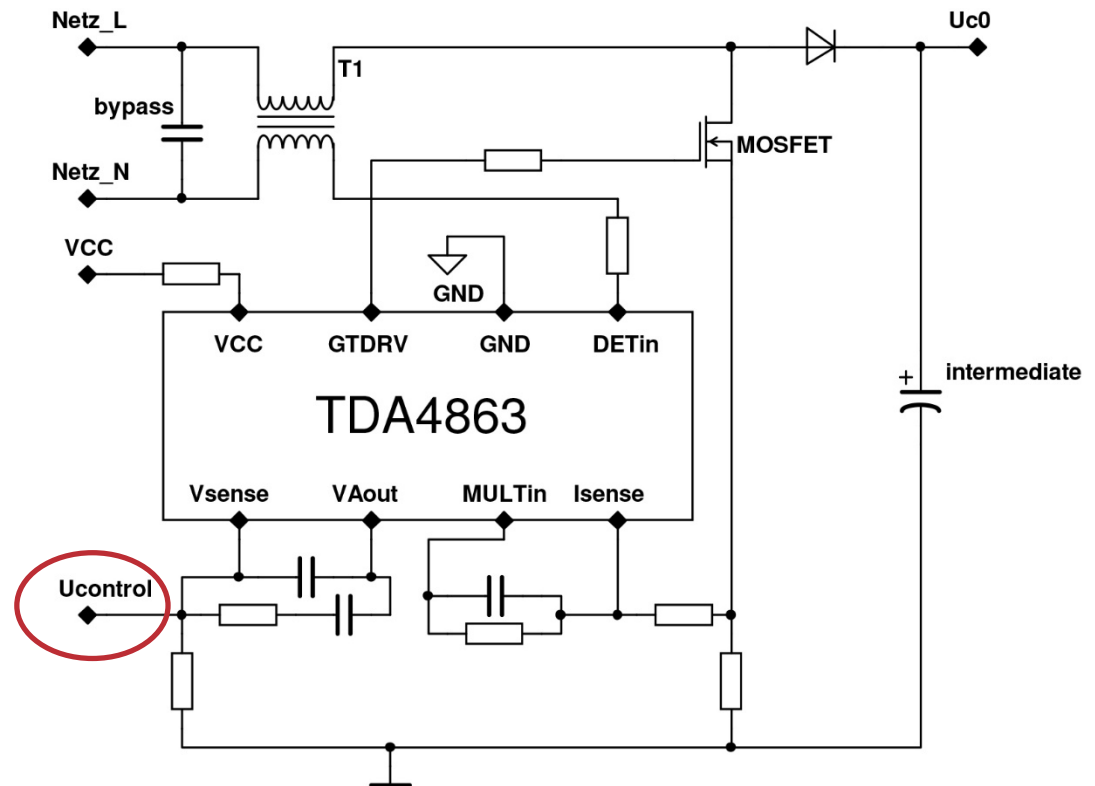

Development process – Control circuit

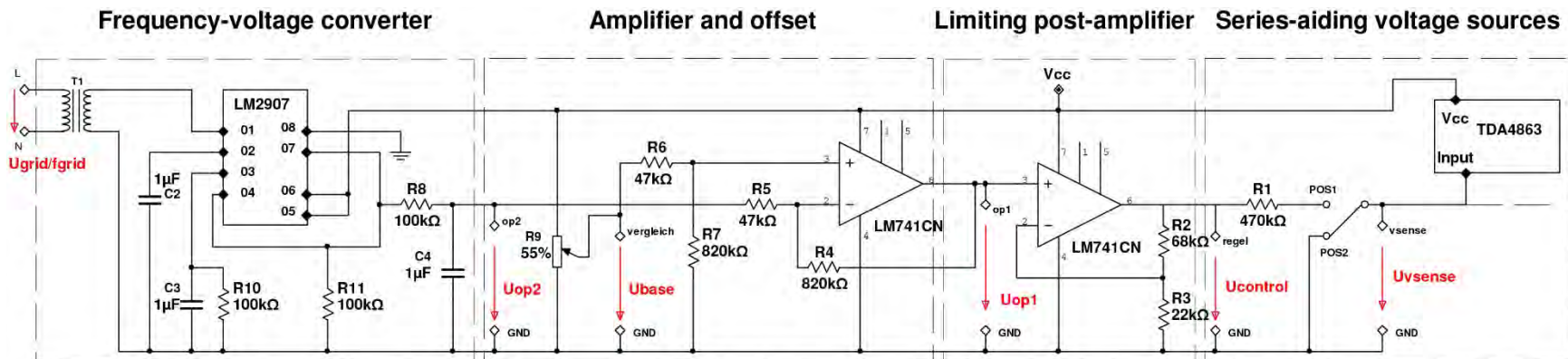

Development process – Triangular control signal

- The *Control voltage* is a signal based on the simulated grid frequency:
 - 6V offset
 - 4V amplitude
 - 1 Hz

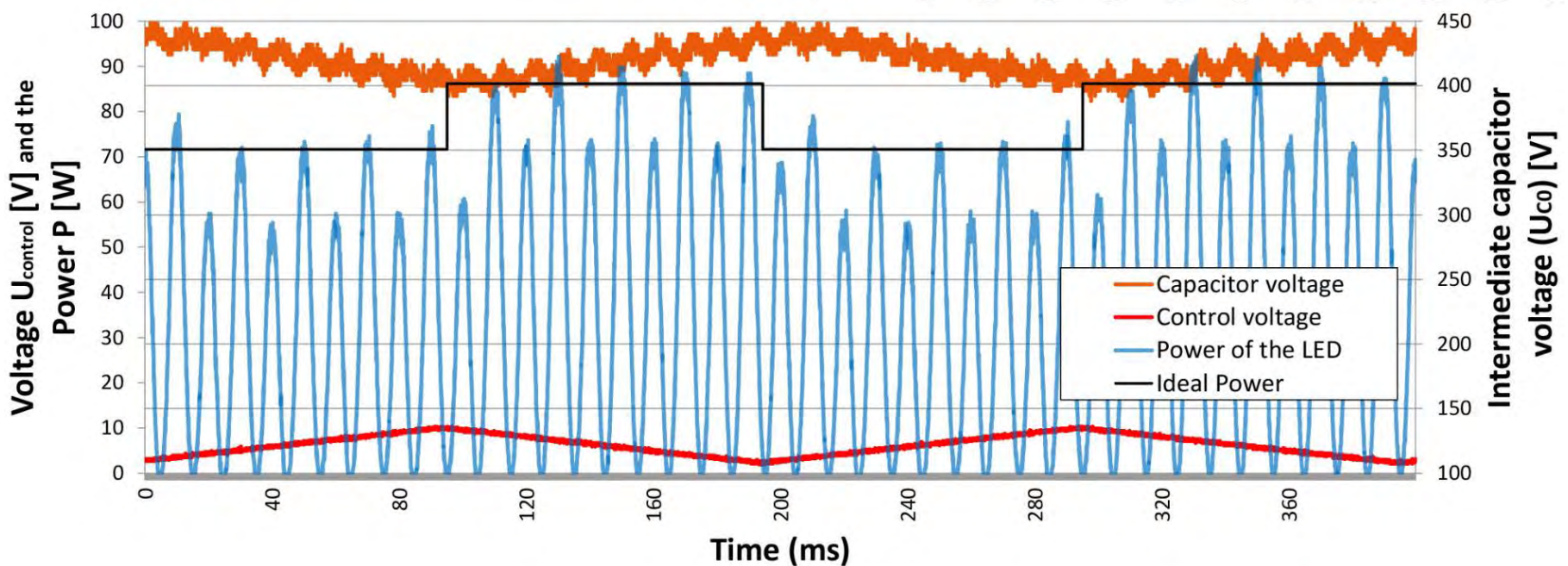

Development process – Synchronous generator

- With a help of an frequency to voltage converter (LM2907)

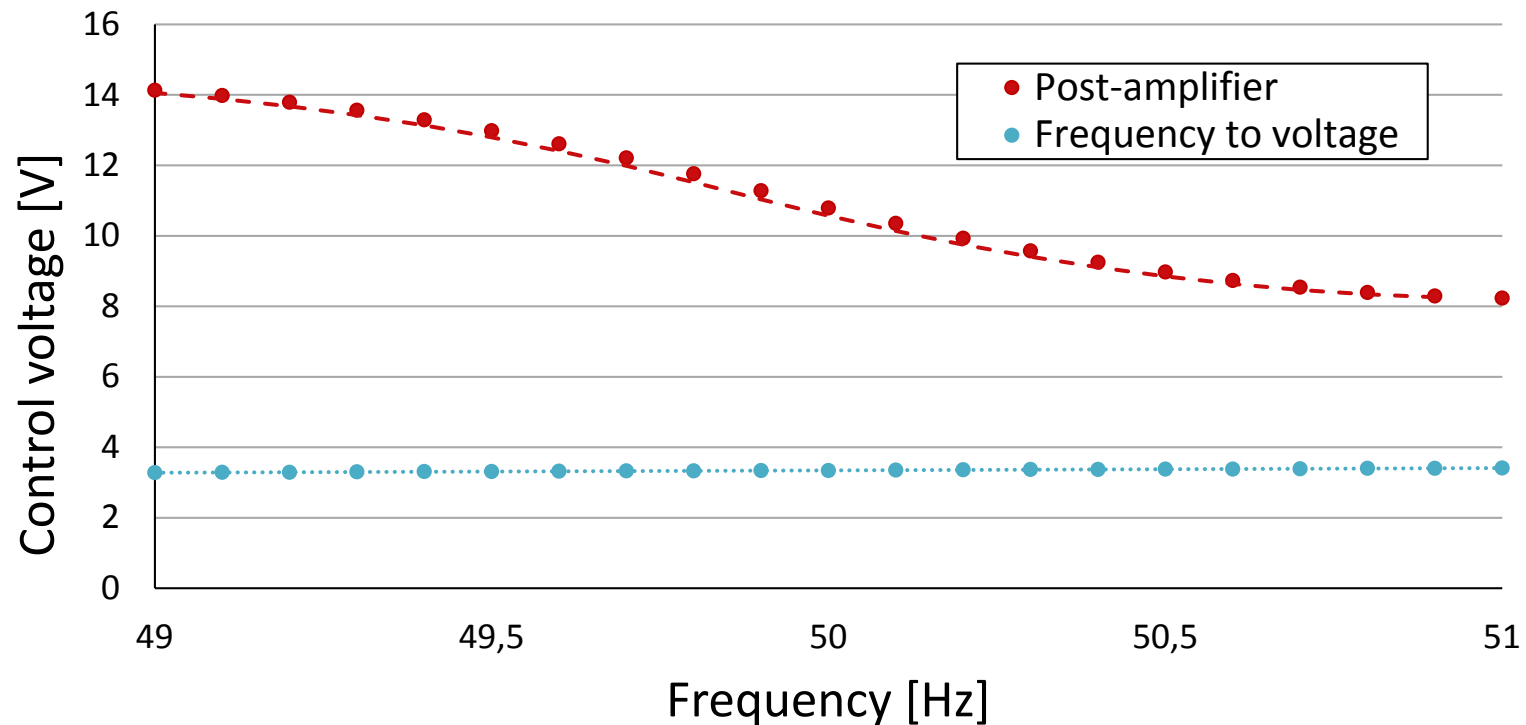

Measurement results

Measured capacitor and control voltage

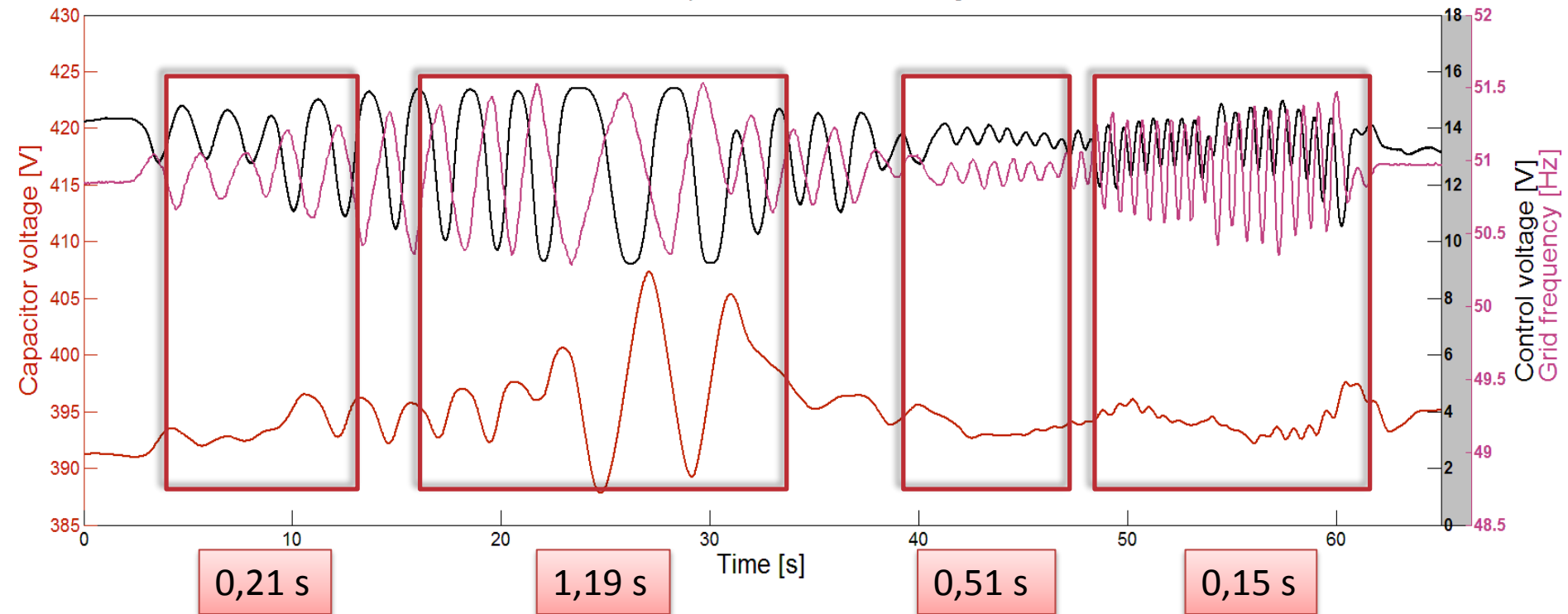

Power consumption

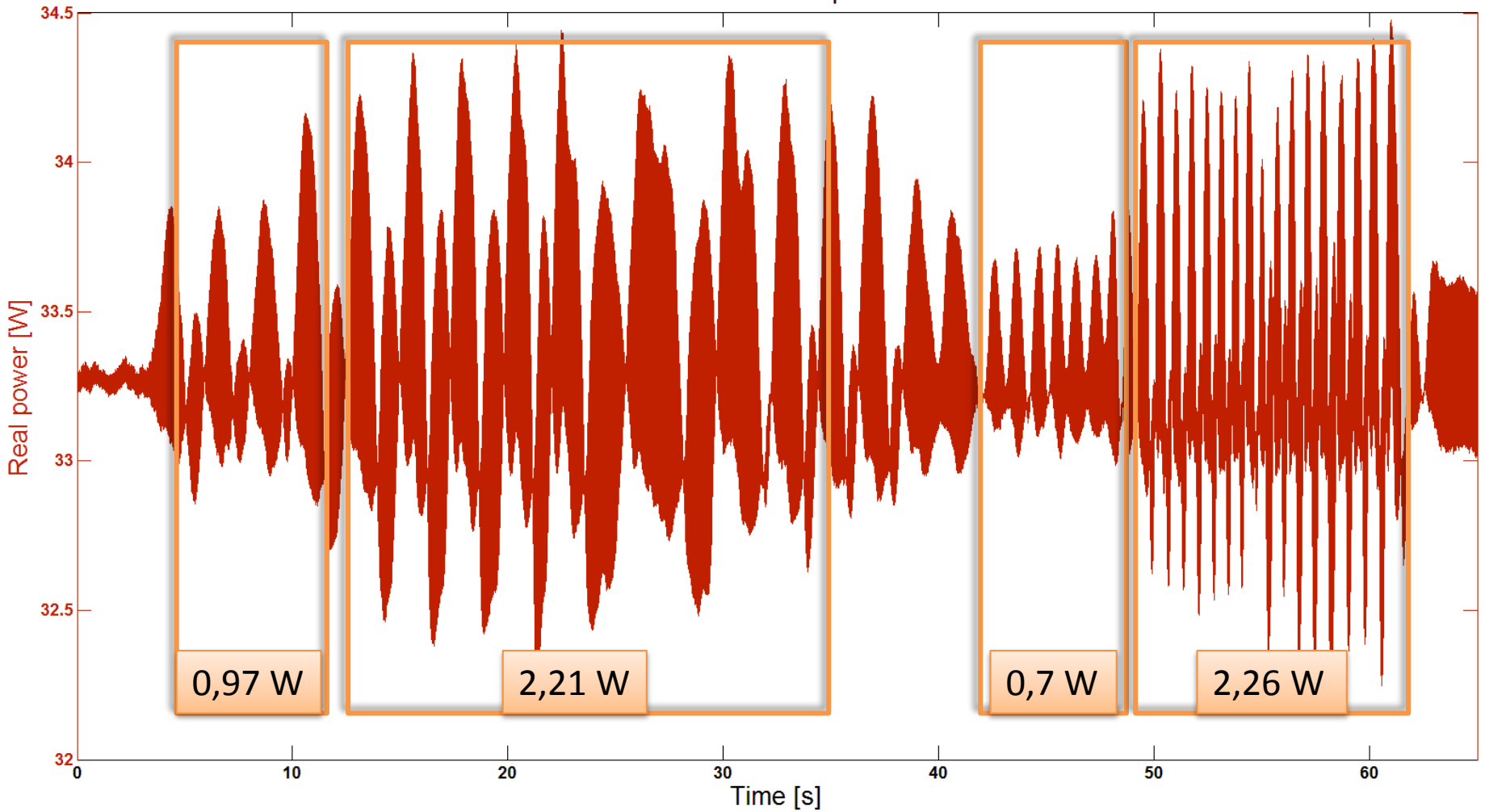

Measurement results

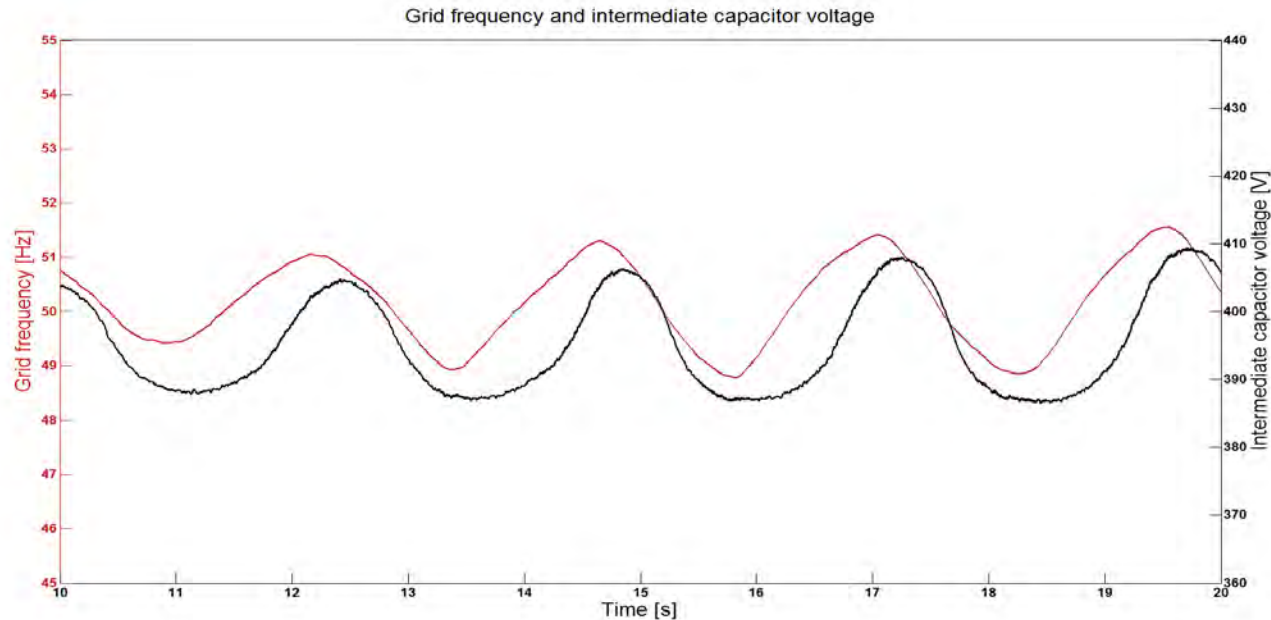

Control speed	Power fluctuation	Frequency
0,21 s	0,97 W	Small gradient, small amplitude
1,19 s	2,21 W	Small gradient, big amplitude
0,51 s	0,7 W	Big gradient, small amplitude
0,15 s	2,26 W	Big gradient, big amplitude

Measurement results

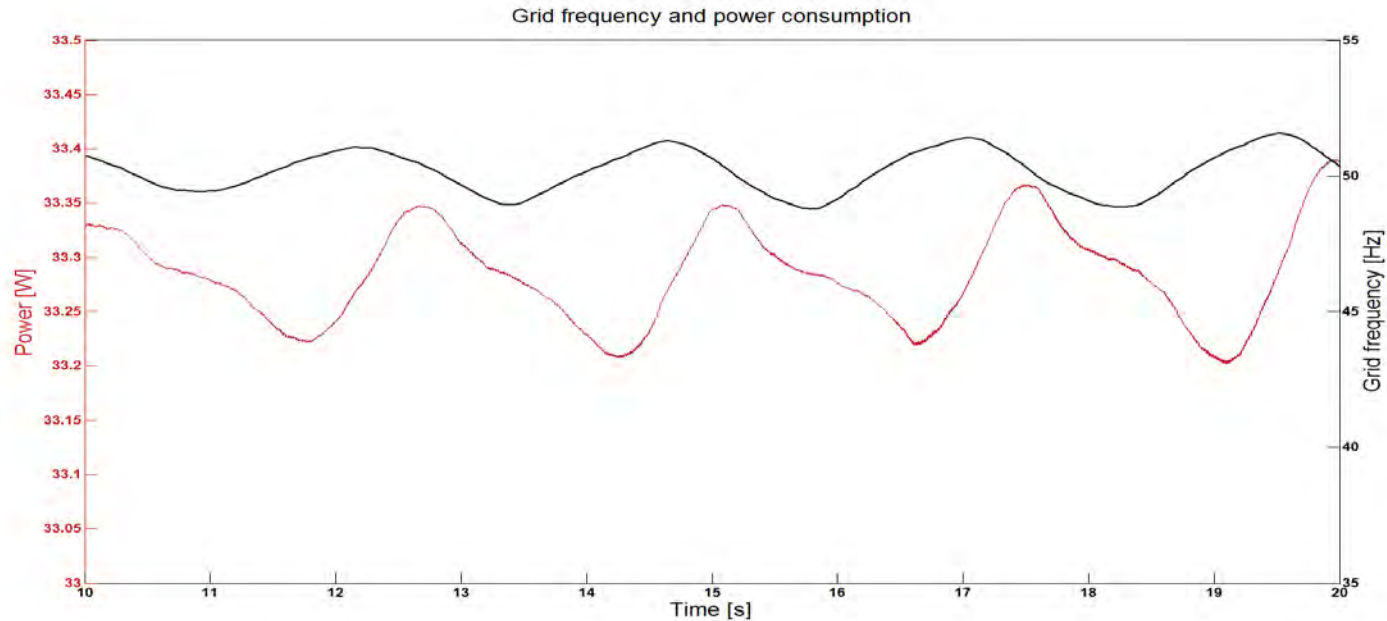

Control speed	Power fluctuation	Frequency
0,21 s	0,97 W	Small gradient, small amplitude
1,19 s	2,21 W	Small gradient, big amplitude
0,51 s	0,7 W	Big gradient, small amplitude
0,15 s	2,26 W	Big gradient, big amplitude

Conclusion

- The designed circuit was able to change the power consumption of the LED lamp driver up to 2.2 W.
- Although this value may be less in case of a daily operation without power failures in an electricity network.
- With this development:
 - The frequency stability of the grid can be maintained
 - No additional hardware is required (cost effective)
 - With the modification of the existing feed-in inverters (easily implemented solution)

References

- [1] A.-C. Agricola, et al., dena-Studie Systemdienstleistungen 2030 – Sicherheit und Zuverlässigkeit einer Stromversorgung mit hohem Anteil erneuerbarer Energien, DENA, Energiesysteme und Energiedienstleistungen, Berlin, 2014.
- [2] E. Waffenschmidt, Momentan-Regelung mit Photovoltaik-Wechselrichtern, Otti-Konferenz "Zukünftige Stromnetze für erneuerbare Energien", Berlin, 2016.
- [3] ON Semiconductor, Power Factor Correction (PFC) Handbook, <http://www.onsemi.com/pub-link/Collateral/HBD853-D.PDF>, angerufen: 21.05.2016, 14:34

